

Artikel: 36-2120 / 36-2120D
Absperrklappe mit Nutanschluss
Butterfly valve grooved ends

Eigenschaften

1. Absperrklappe mit Nutenden.
2. Gehäuse und Klappenscheibe EN-GJS-400 (GGG40).
3. Klappenscheibe EPDM-ummantelt
4. gefertigt gemäß API 609.
5. Baulänge MSS SP-67.
6. Nutenden gemäß AWWA C606.
7. Innen und aussen epoxy-beschichtet RAL 3000.
8. max. Betriebsdruck 300 PSI.
9. max. Betriebstemperatur: 80°C.

Features

1. Butterfly valve grooved ends.
2. Made of Ductile Iron EN-GJS-400 (GGG40).
3. Butterfly disc of ductile iron coated EPDM.
4. Design according to API 609.
5. Face to Face according to MSS SP-67.
6. Grooved ends according to AWWA C606.
7. Inside & Outside with Epoxy coating RAL 3000.
8. Working pressure 300 PSI.
9. Max. Working temperature 80°C.

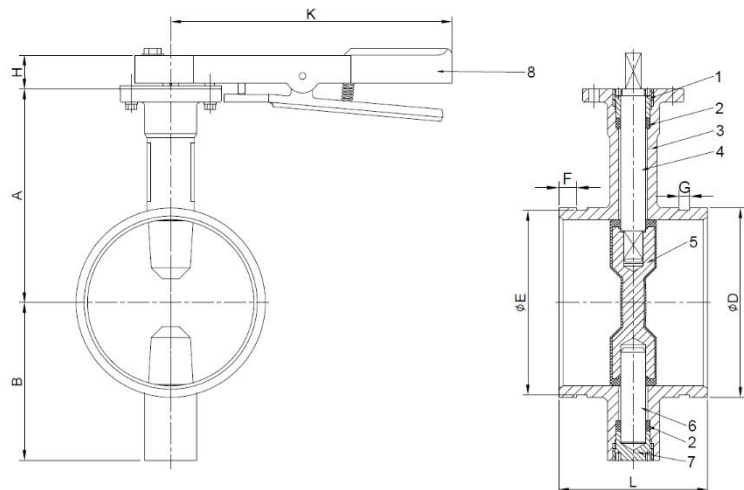

n°	Bauteilbezeichnung / Name	Material	Oberflächenschutz / Surface Treatment
1	Wellenmutter oben/ Upper shaft nut	C-Stahl / Carbon steel	-----
2	Wellendichtung oben / Shaft seal	EPDM	-----
3	Gehäuse / Body	Sphäroguss / Ductile Iron EN-GJS-400	Epoxy
4	Schaltwelle/ Upper shaft	Edelstahl / Stainless Steel AISI 416	-----
5	Klappenscheibe / Disc	Fund. nodular / Ductile Iron + EPDM	-----
6	Lagerwelle unten / lower shaft	Acero Inox. / Stainless Steel AISI 416	-----
7	Wellenmutter unten / Lower shaft nut	Acero carbono / Carbon steel	-----
8	Handhebel mit Rasterscheibe / Handle	Grauguss / Cast Iron EN-GJS-200	lackiert /Painted

Hauptabmessungen / GENERAL DIMENSIONS:

Artikel 36-	Medida / Size	Dimensiones / Dimensions (mm)											
		L	D	E	F	G	A	B	H	K	J	P	Kg
2120 09	2"	81	60.3	57.2	15.9	7.9	110	85	32	267	----	----	2,5
2120 10 2120D 10	2 ½" DN65	96.8	73 (*) 76.1 (**)	69.1 72.3	15.9	7.9	125	95	32	267	----	----	3
2120 11	3"	96.8	88.9	84.9	15.9	7.9	140	100	32	267	----	----	3,5
2120 12	4"	115.8	114.3	110.1	15.9	9.5	160	100	32	267	----	----	4,8
2120 13 2120D 13	5" DN125	147.6	141.3 (*) 139.7 (**)	137 135.5	15.9	9.5	170	125	32	267	----	----	7,6
2120 14 2120D 14	6" DN150	147.6	168.3 (*) 165.1 (**)	164 160.9	15.9	9.5	190	140	32	267	----	----	9,5
2120 16	8"	133.4	219.1	214.4	19	11.1	200	175	37	353	----	----	17,4
2120 18	10"	158.8	273	268.3	19	12.7	260	200	77	----	233	290	35,5
2120 20	12"	165.1	323.9	318.3	19	12.7	300	240	77	----	226	290	50

(*) Für Rohr / For Pipe: ASME B 36.10
 (**) Für Rohr / For Pipe: UNE-EN 10255

*** **Achtung: von 2" bis 8" erfolgt die Betätigung mittels Hamdhebel/ From 2" to 8" cast iron handle.**
Ab 10" erfolgt die Betätigung mittels Getriebe und Handrad / From 10", handling by gear box.

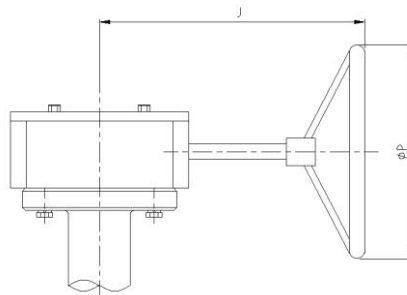

10" ~ 12"

Kopfflanschabmessungen / Top flange dimensions:

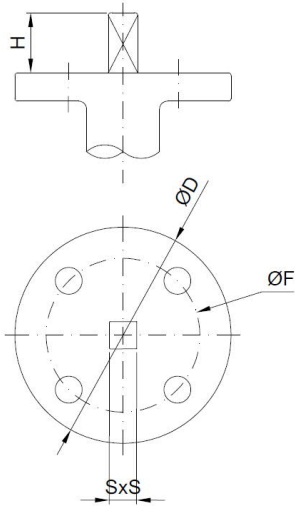

Top flange dimensions						
2120 / 2120D	DN	F (ISO5211)	S	D	H	Torque N·m
09	50	F07	10	65	32	25
10	65	F07	10	65	32	32
11	80	F07	11	65	32	55
12	100	F07	14	90	32	90
13	125	F07	14	90	32	100
14	150	F07	16	90	32	130
16	200	F10	19	125	32	175
18	250	F10	22	125	45	250
20	300	F12	26	150	45	400